

Component Programming with C# and .NET

- 1st Class Component Support
- Robust and Versionable
- Creating and using attributes
- API integration
 - DLL import
 - COM support
- Preserve Existing Investments

What defines a component?

- What defines a component?
 - Properties, methods, events
 - Design-time and runtime information
 - Integrated help and documentation
- C# has first class support
 - Not naming patterns, adapters, etc.
 - Not external files
- Easy to build and consume

Properties

- Properties are “smart fields”
 - Natural syntax, accessors, inlining

```
public class Button: Control
{
    private string caption;

    public string Caption {
        get {
            return caption;
        }
        set {
            caption = value;
            Repaint();
        }
    }
}
```

```
Button b = new Button();
b.Caption = "OK";
String s = b.Caption;
```

Indexers

- Indexers are “smart arrays”
 - Can be overloaded

```
public class ListBox: Control
{
    private string[] items;

    public string this[int index]{
        get {
            return items[index];
        }
        set {
            items[index] = value;
            Repaint();
        }
    }
}
```

```
ListBox listBox = new ListBox();
listBox[0] = "hello";
Console.WriteLine(listBox[0]);
```

Events

- Efficient, type-safe and customizable
 - Built on delegates

```
public class MyForm: Form {  
    public MyForm()  
    {  
        Button okButton = new Button(...);  
  
        okButton.Click += new EventHandler(OkButtonClick);  
    }  
  
    void OkButtonClick(...)  
    {  
        ShowMessage("You clicked OK");  
    }  
}
```

Design/Runtime Information

- Add information to types + methods?
 - Transaction required for a method?
 - Mark members for persistence?
 - Default event hookup?
- Traditional solutions
 - Lots of custom user code
 - Naming conventions between classes
 - External files (e.g. .IDL, .DEF)
- The C# solution - Attributes

Attributes

- Appear in square brackets
- Attached to code elements

```
[HelpUrl("http://SomeUrl/Docs/SomeClass")]  
class SomeClass  
{  
    [WebMethod]  
    void GetCustomers() { ... }  
  
    string Test([SomeAttr] string param1) {...}  
}
```

Attribute Fundamentals

- Attributes are classes! Completely generic

```
class HelpUrl : System.Attribute {  
    public HelpUrl(string url) { ... }  
    ...  
}
```

```
[HelpUrl("http://SomeUrl/APIDocs/SomeClass")]  
class SomeClass { ... }
```

- Easy to attach to types and members

```
Type type = Type.GetType("SomeClass");  
object[] attributes =  
    type.GetCustomAttributes();
```

- Attributes can be queried at runtime

Attributes in .NET

- Web Services
- COM Interop
- Platform Invoke (DLL Interop)
- Transaction Contexts
- Permissions
- Custom XML Persistence
- **User-defined attributes to specify non-functional component properties (RT / FT / Security / Config.)**

XML Comments

- XML schema for comments
 - Method description
 - Parameter types, names and descriptions
 - Add your own tags - just XML
- Compiler and IDE support
 - Compiler creates XML file for all classes
 - IDE support for entry and display
- Used throughout .NET Framework

Using Attributes

```
[HelpUrl("http://SomeUrl/APIDocs/SomeClass")]
class SomeClass
{
    [Obsolete("Use SomeNewMethod instead")]
    public void SomeOldMethod()
    { ... }

    public string Test( [SomeAttr()] string param1 )
    { ... }
}
```

Using Attributes (contd.)

```
[HelpUrl("http://SomeUrl/MyClass")]  
class MyClass {}
```

```
[HelpUrl("http://SomeUrl/MyClass", Tag="ctor")]  
class MyClass {}
```

```
[HelpUrl("http://SomeUrl/MyClass"),  
 HelpUrl("http://SomeUrl/MyClass", Tag="ctor")]  
class MyClass {}
```

Querying Attributes

```
Type type = typeof(MyClass);  
foreach(object attr in type.GetCustomAttributes() )  
{  
    if ( attr is HelpUrlAttribute )  
    {  
        HelpUrlAttribute ha = (HelpUrlAttribute) attr;  
  
        myBrowser.Navigate( ha.Url );  
    }  
}
```

Replication based on Attributes

- Specification of a component's non-functional properties at design time
- A tool may generate code to automatically create replicated objects
- Component behavior described by user-defined attributes

```
namespace CalculatorClass {  
    using System; using proxy;  
  
    [TolerateCrashFaults(4)]  
    public class Calculator {  
        ...  
        public double add  
            (double x, double y) {  
            return x + y;  
        }  
    }  
}
```

Behind the scenes...

```
public sealed class Calculator:CalculatorClass.Calculator {  
    private CalculatorClass.Calculator[] _bc;  
    public Calculator(): base() {  
        _ErrorCount=0; int _Count=1;  
        System.Attribute[] _arAtt =
```

Reflection



```
        System.Attribute.GetCustomAttributes(GetType());
```

Attribute-based
programming



```
        foreach(System.Attribute _attr in _arAtt) {  
            if(_attr is TolerateCrashFaults)  
                _Count=((TolerateCrashFaults)_attr).Count;  
        }  
        /// creation of sufficiently many proxy objects  
        _bc=new CalculatorClass.Calculator[_Count];
```

From the consumer's perspective

```
namespace CalculatorFront {  
    using System;  
    /// using CalculatorClass; ←  
    using proxy;  
  
    public class MainClass {  
        public MainClass() {}  
        public static int Main(string[] args) {  
            Calculator calc = new Calculator();  
            ...  
            result = calc.add(val1, val2);  
        }  
    }  
}
```

Minimal code
changes

Calling Into Existing DLLs

- .NET Framework contains attributes to enable calling into existing DLLs
- `System.Runtime.InteropServices`
 - DLL Name, Entry point, Parameter and Return value marshalling, etc.
- Use these to control calling into your existing DLLs
 - System functionality is built into Framework

Attributes to specify DLL Imports

```
[DllImport("gdi32.dll")]
```

```
public static extern
```

```
    int CreatePen(int style, int width, int color);
```

```
[DllImport("gdi32.dll", CharSet=CharSet.Auto)]
```

```
public static extern
```

```
    int GetObject( int hObject,  
                  int nSize,  
                  [In, Out] ref LOGFONT lf);
```

COM Support

- .NET Framework provides great COM support
 - TLBIMP imports existing COM classes
 - TLBEXP exports .NET types
- Most users will have a seamless experience

Calling into a COM component

- Create .NET assembly from COM component via **tlbimp**
- Client apps may access the newly created assembly

```
using System;
using System.Runtime.InteropServices;

using CONVERTERLib;

class Convert {
    public static void Main(string [] args) {
        CFConvert conv = new CFConvert();
        ...
        fahrenheit = conv.CelsiusToFahrenheit( celsius );
    }
}
```

COM Support

- Sometimes you need more control
 - Methods with complicated structures as arguments
 - Large TLB – only using a few classes
- `System.Runtime.InteropServices`
 - COM object identification
 - Parameter and return value marshalling
 - HRESULT behavior

COM Support Example

```
[Guid("56A868B1-0AD4-11CE-B03A-0020AF0BA770")]  
interface IMediaControl  
{  
    void Run();  
    void Pause();  
    void Stop();  
    ...  
    void RenderFile(string strFilename);  
}
```

The Evolution of Components (Microsoft-style)

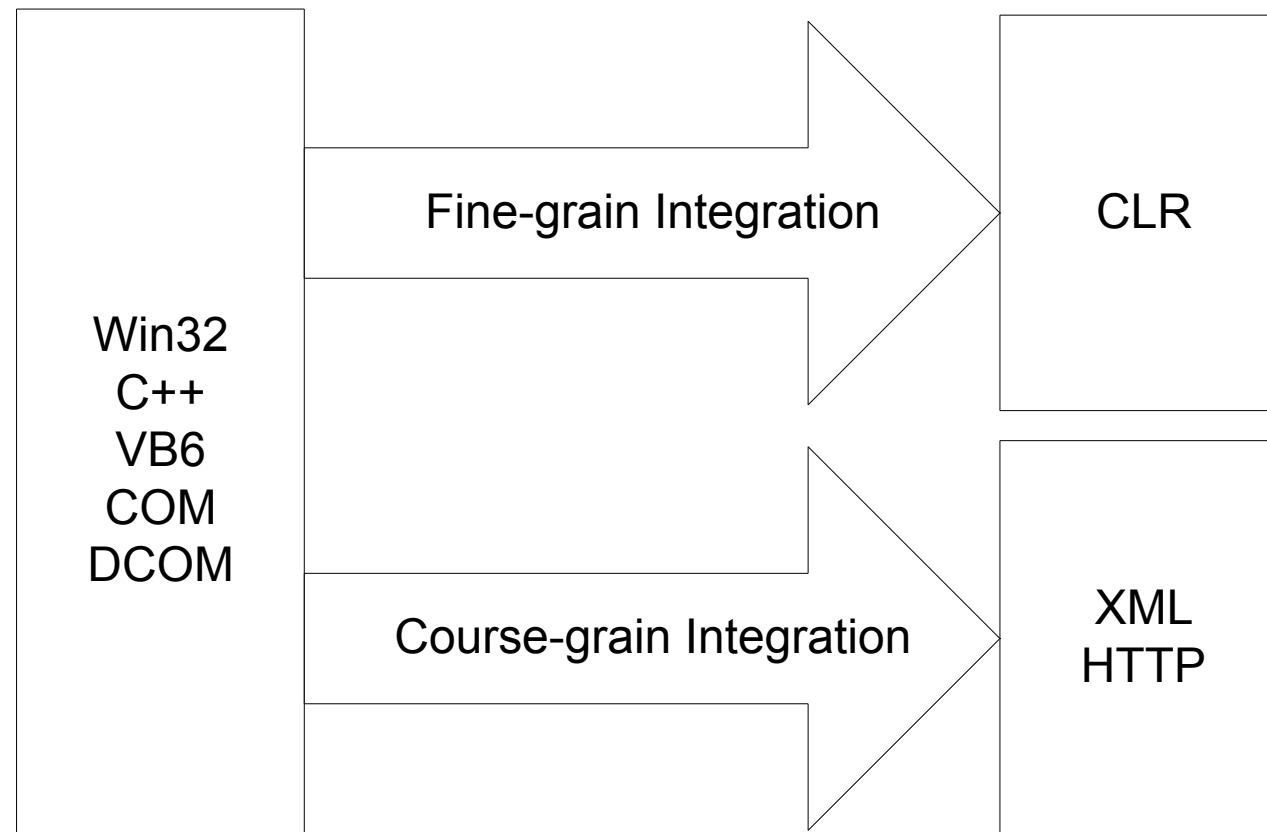

Type fragmentation under COM

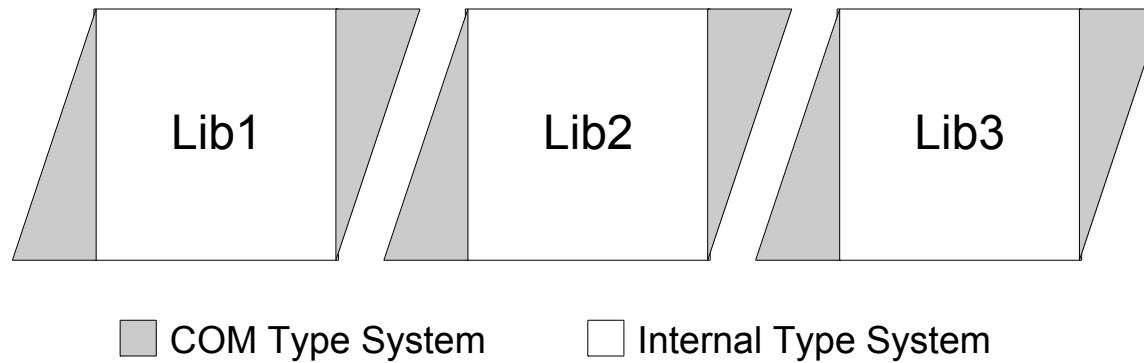

Pervasive Type in the CLR

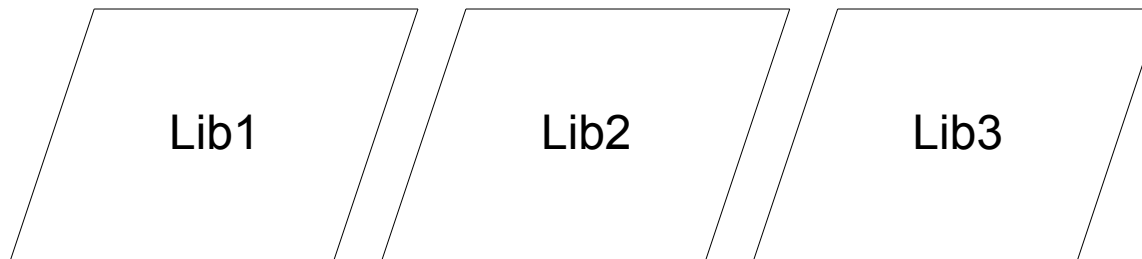

CLR Type System

Type segregation under XML

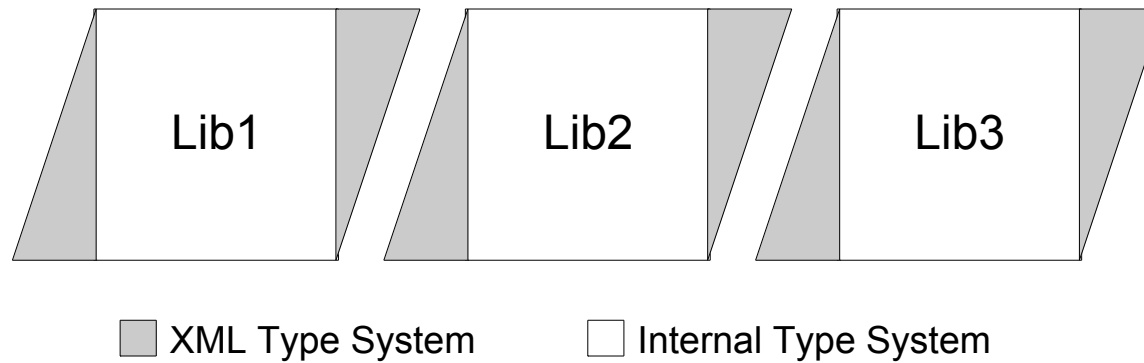

Object Creation and the Loader

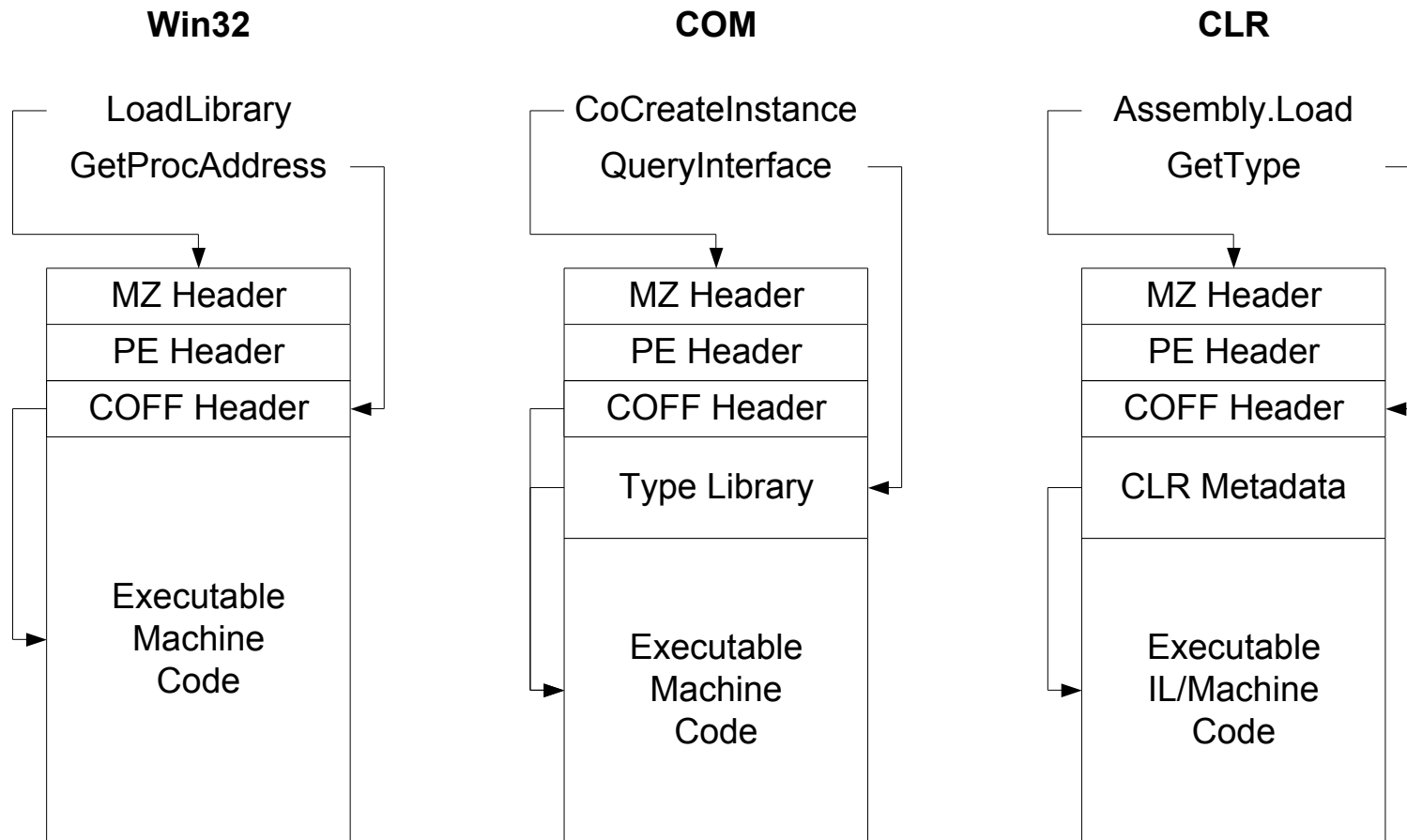

CLR Architecture

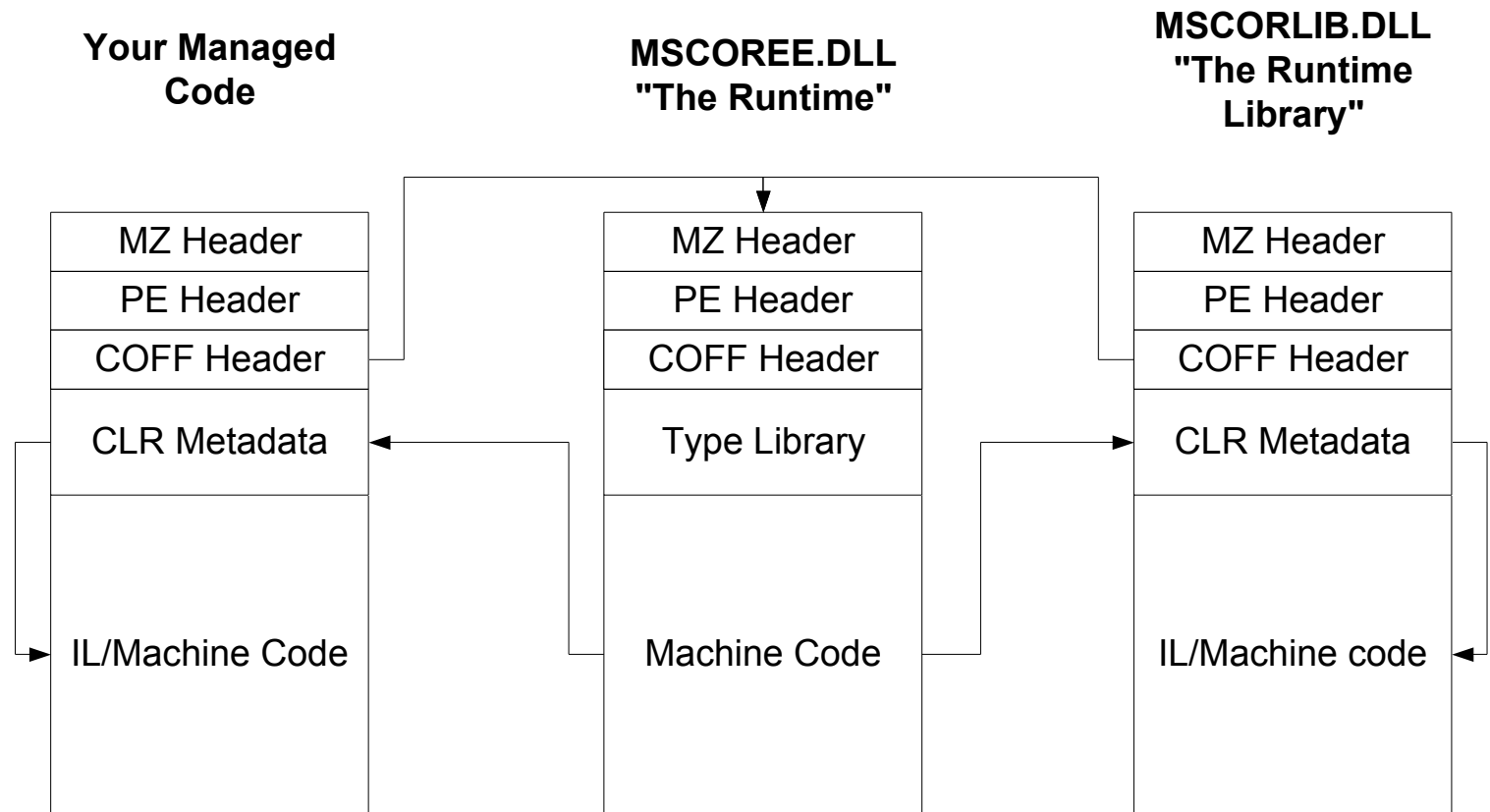

on-the-fly COM

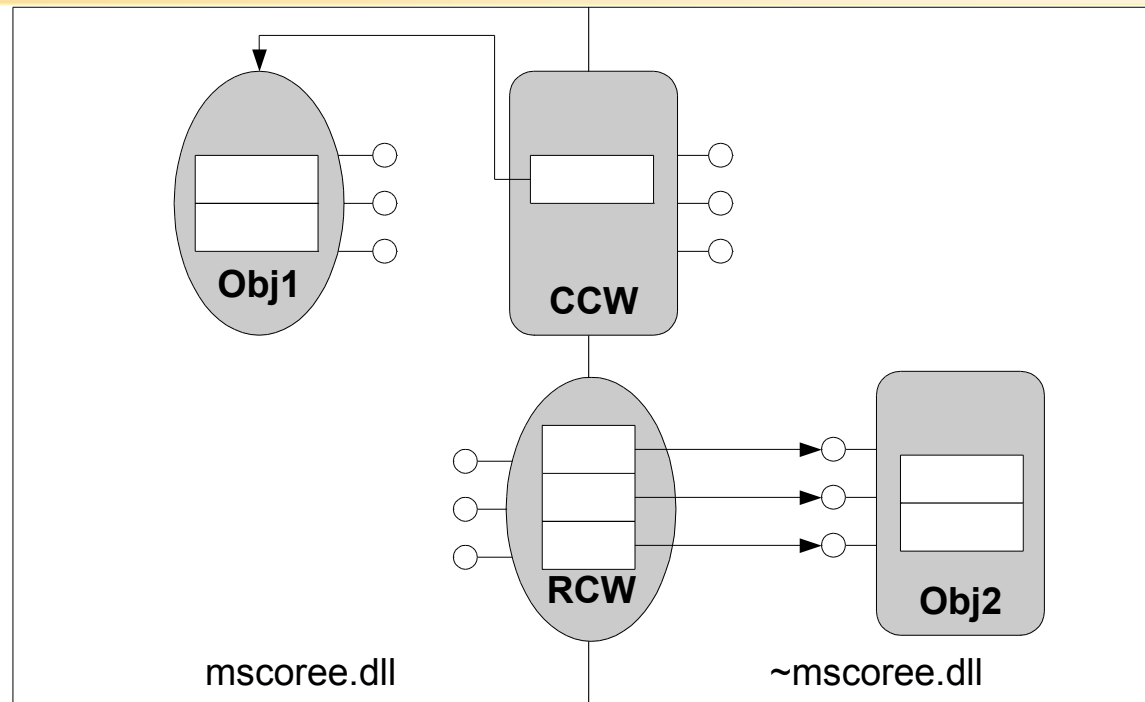

- COM callable wrapper (CCW)
- runtime callable wrapper (RCW)

The CLR Type System

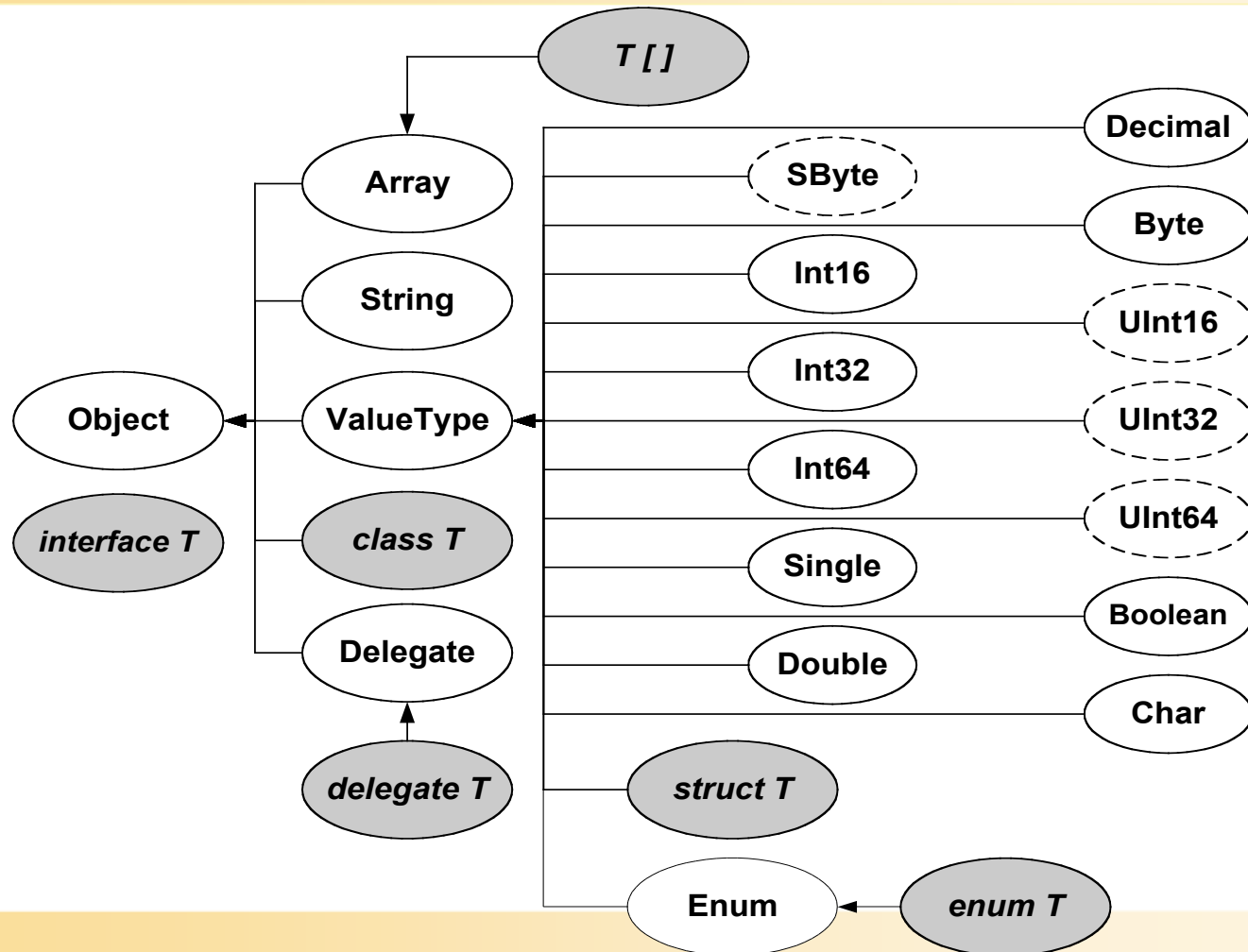

Metaprogramming and Reflection in .NET

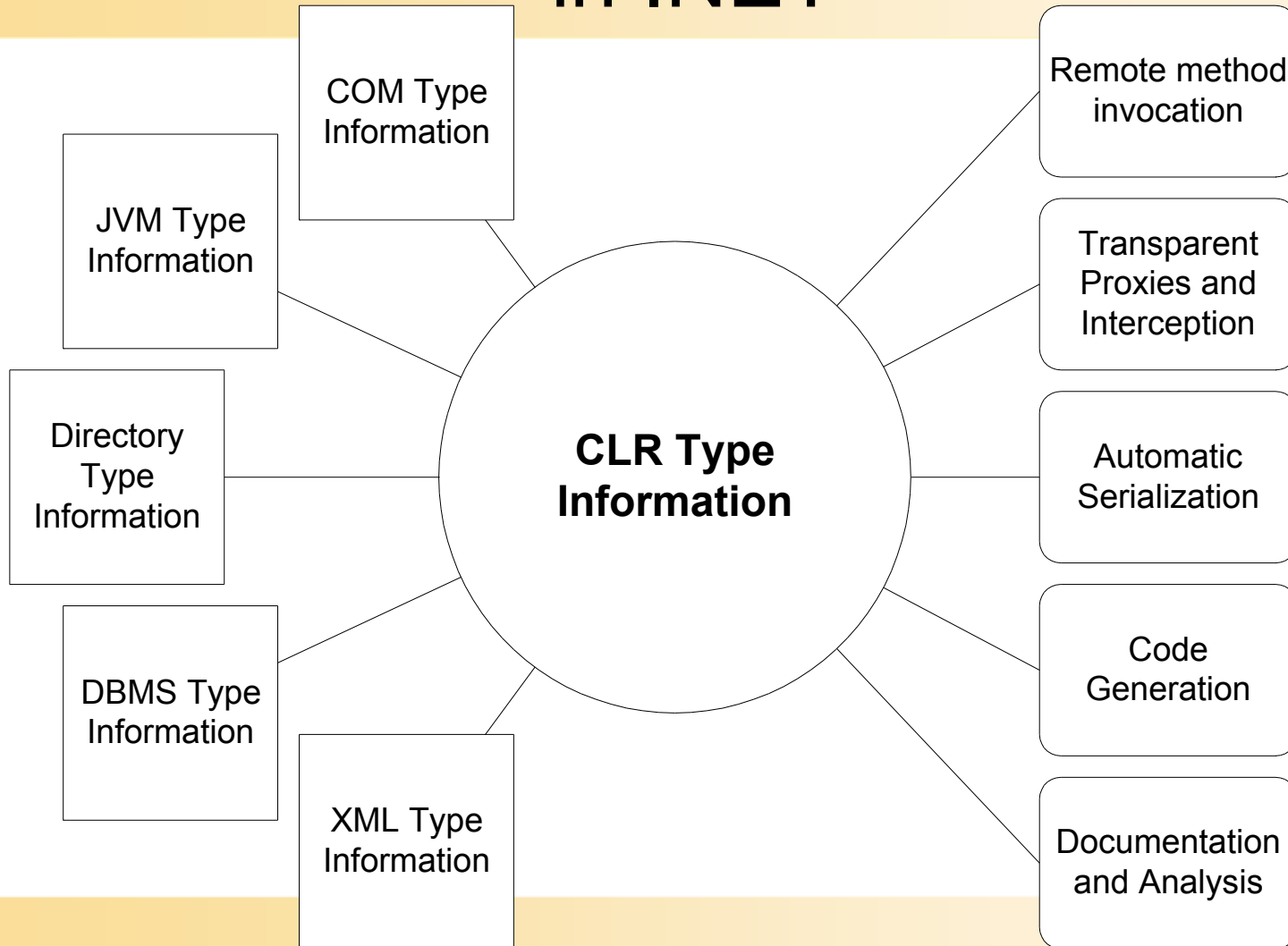

Pervasive type and GetType

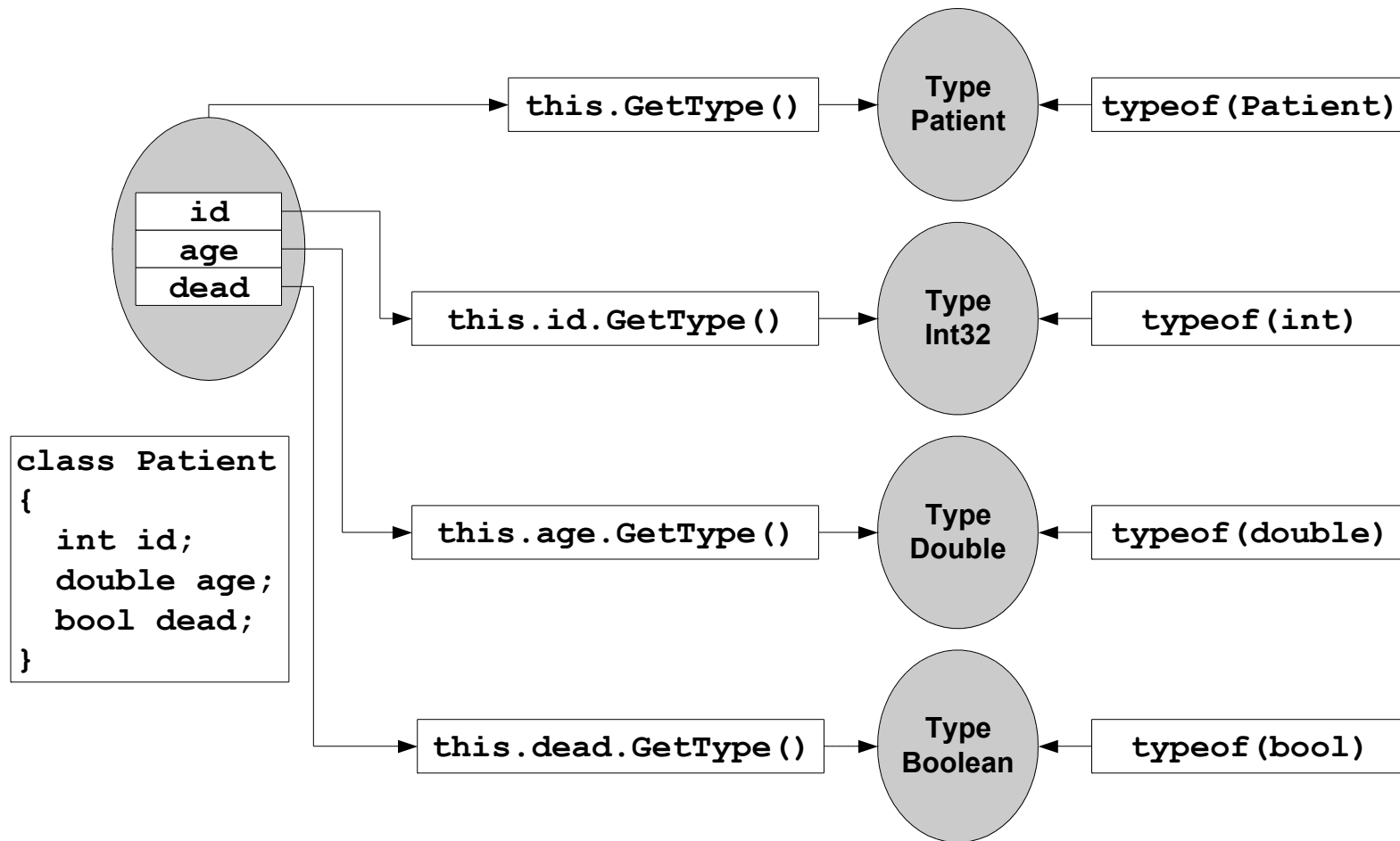

Pervasive type and System.Type

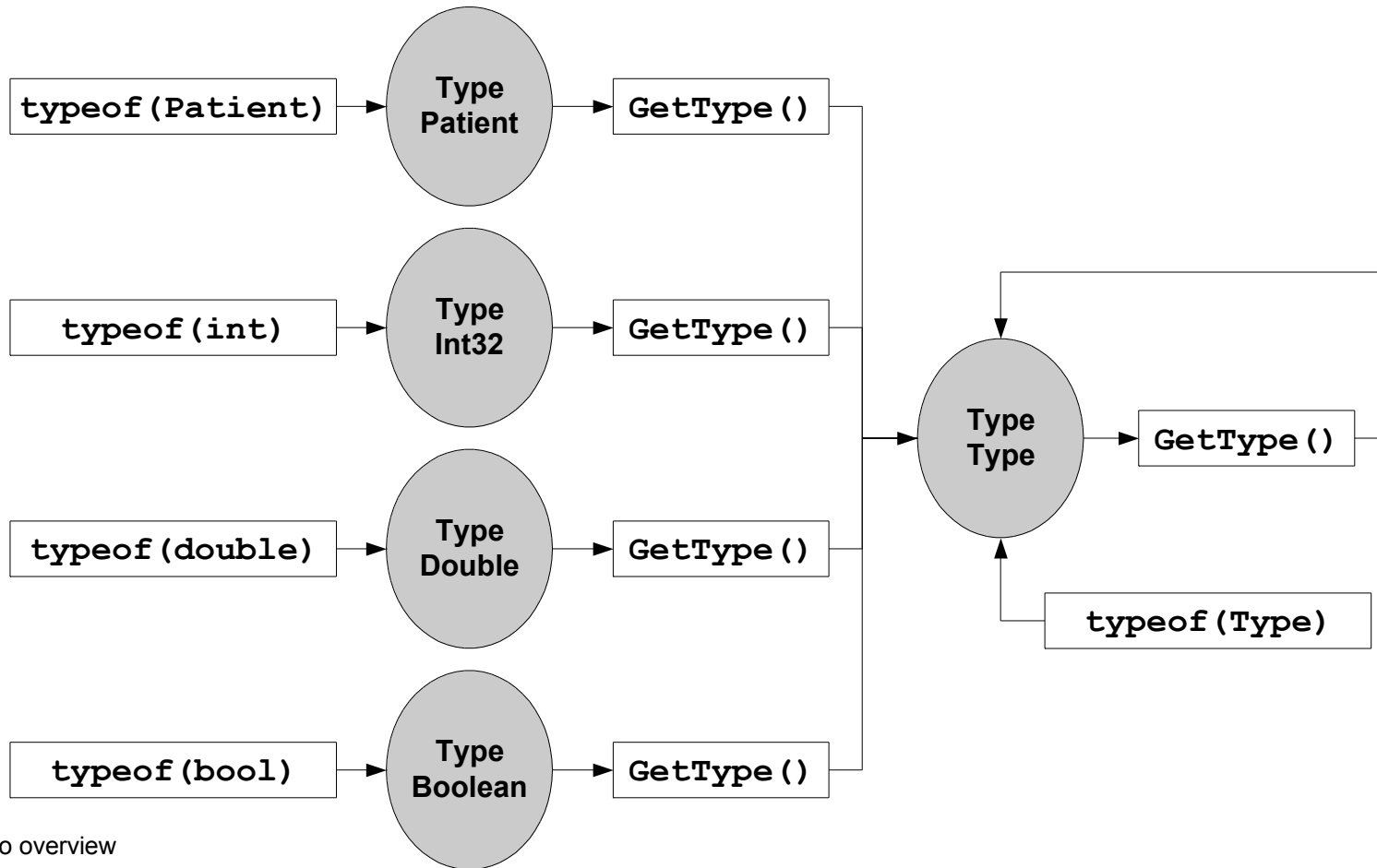

[Back to overview](#)